

WC Sense Flush Valve – Duct Type

PRODUCT FEATURES

- Automatic infra-red sensor activation water closet flush valve
- Heavy duty S/S grade 304 cover plate with satin finish
- Automatic sensor adjustment on installation
- Piston valve with build-in stainless steel strainer for screening out the debris and self-cleaning solenoid
- Electrical sensor is isolated and sealed in waterproof compartment
- Dual flush manual override button incorporated
- Complete with 1-1/4" vacuum breaker set

PRODUCT SPECIFICATIONS

- Dimension : 140 (L) x 140 (H) mm
- Material : Brass casting flush valve with stainless steel satin finish panel
- Power Supply : 230VAC 50Hz
- Water Supply : BSPT G 1"
- Detection Time : 7 seconds minimum
- Detection Range : Self-adjusting to environment
- Operating Temperature : 0-40° C
- Supply Pressure : 135 kPa (flowing) – 860 kPa (minimum flow rate of 90 litre/minute)
- Trap Seal Protection : Automatically flush once every (24) hours of non-use (optional)

DISCHARGE VOLUME

- Full Flush : 4.5L per flush
- Reduced Flush : 3.0L per flush



RESOURCEFUL FEATURES:



Hold-Flow Flushing



Auto-Adjust Sensing



RC1000 Remote Control



Build in Manual Overriding Button



Dual Flush Mechanism

TECHNICAL DRAWING

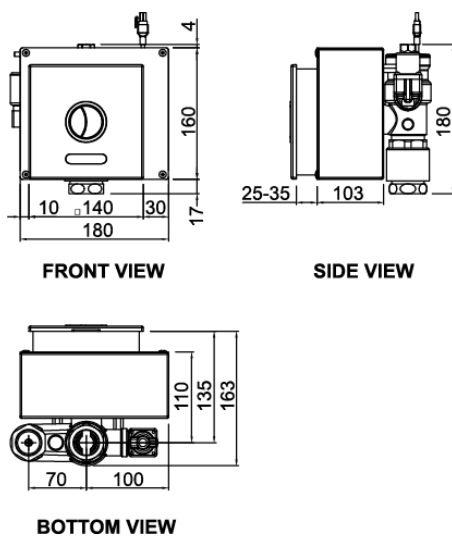

INSTALLATION DETAILS

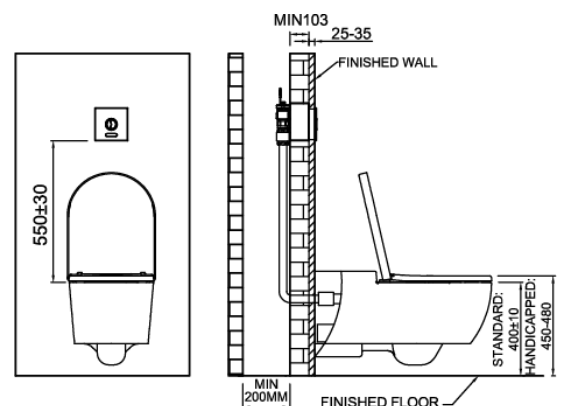

STANDARD (*)
400±10 from floor finishing to the rim of water closet

HANDICAPPED (#)
450-480 from floor finishing to the top of the water closet seat